

Specifications

- Tweeter: 1" Silk Dome ± 3 dB Tuning
- Woofer: 6.5" Kevlar Cone Rubber Surround ± 3 dB Tuning
- Impedance: 8Ω
- Sensitivity: 86 ± 3 dB
- Frequency Range: 45Hz~20KHz
- Power Handling RMS: 100W
- Cut Out Dimensions: 13" x 8" (330mm x 202mm)
- Magnetic Grill Cover
- 2 Piece Frame Design Installation

5-YEAR LIMITED WARRANTY

Rave Technology products are warranted to be free from defects in workmanship and materials for a period of Five (5) years from the date of purchase without charge for parts or labor. This warranty does not apply to units that have been subject to misuse, abuse, neglect or improper installation, and does not apply to repairs or alterations made by unauthorized professional. This warranty specifically excludes responsibility for consequential damage. Retention of your original bill of sale is required to obtain service under the terms of this warranty.

© 2020 Rave Technology. All rights reserved.

All trademarks are the property of their respective owners.

Specifications are subject to change without notice.

Rave Technology
4100 East Baldwin Road Holly,
Michigan, 48442 USA
Tel: 866-303-2629
contact@ravetechnology.com



RK2IW-650P In-Wall Speaker

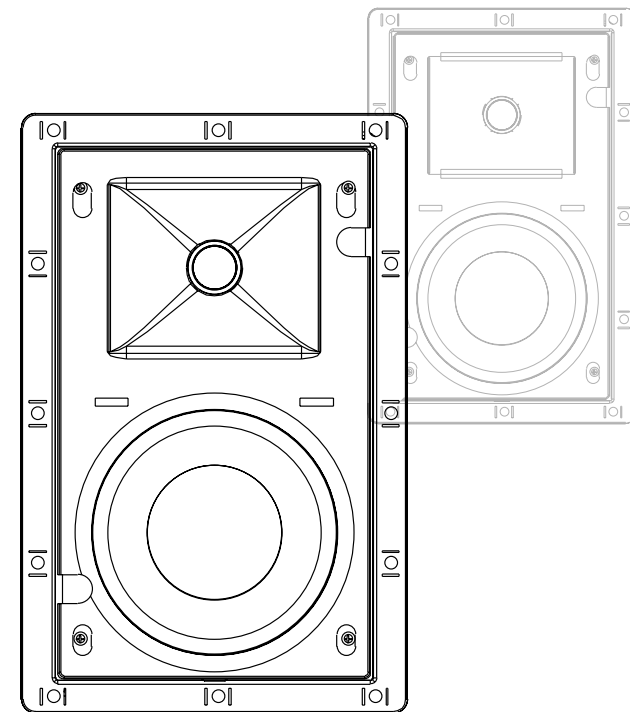



Warnings and Safety



Please read the instructions carefully before installation and use. Keep the manual safe for future reference.

- Prior to installing the speakers into any ceiling or wall, check the structure for weight bearing ability and avoid contact with any wiring or plumbing that might be behind the surface area.
- Installing on soft materials or in areas incapable of supporting the speakers weight may cause personal injury or damage to the speaker.
- When installing speakers outside, choose areas such as the underside of eaves to avoid strong direct weather and sunlight which may affect the color and life of the speaker enclosure.
- When placing the speakers on a wall or shelf, it is recommended that speakers be installed at the level of the ear or higher.
- Damage to the woofer and tweeter may occur if the speaker is dropped or hit - resulting in no sound or distorted sound.
- Use only approved and certified wiring in your installation, do not stretch or place the wire in contact with sharp objects.
- Never overdrive your speakers to the point of distortion and always reduce volume prior to switching input sources.
- Turn off the power to the speaker when unused for long periods of time.
- Direct sun and/or bad weather exposure can damage your speakers. We recommend you to place your speakers in a sheltered location (under an overhang) and to remove them in the winter.
- Rave RK Series speakers require a run-in period before they deliver their best performance. They must get adapted to the temperature and humidity conditions of their environment. This breaking-in period depends on the encountered conditions and can last several weeks. However, you can shorten this period by letting your loudspeakers operate for about twenty hours at moderate volume.

Rave speakers are designed for standard wall, ceiling or drop ceiling applications. Please refer to the installation guidelines below for the best speaker placement for your audio application.

Stereo Placement

In a standard two channel (stereo) audio, the speakers should be installed approximately 6 to 10 feet apart. If possible, the left and right speakers should be located the same distance from the listening position. The pivoting adjustable tweeters that are useful to focus the audio in the direction of the intended listening location.

Surround (5.1) Placement

These speakers should be installed approximately 6 to 10 feet apart. When using the speakers as rear channels, the speakers should be located from 2 to 6 feet behind the main listening position and 6 to 10 feet apart.

Distributed Audio Placement

Rave Technology speakers possess extremely smooth and predictable off-axis frequency response. The chart below shows how far apart the speakers can be placed in a distributed audio system. The calculations are based on +/- 45 degrees of coverage from the speaker, and listener ear heights of 62" for standing and 40" for seated listener.

Speakers spacing	Standing Listener	Seated Listener
8 foot ceiling	5.7'	9.5'
10 foot ceiling	9.7'	13.5'
12 foot ceiling	13.7'	17.5'
14 foot ceiling	17.7'	21.5'

Wire Gauge and Quality

The total wire resistance should be less than 10% of the speaker impedance. If using an 8 ohm speaker, your total wire resistance should be no more than 8 ohms.

In simple terms, the extra resistance from the wire will have a very negative effect on the sound quality of the speaker. The sound can be less dynamic, definition of bass frequencies can be reduced, and in extreme cases, the high frequencies can be attenuated. Amplifier power is also wasted in the wire, reducing the maximum output level of the system. Please refer to the following chart when deciding on the appropriate wire gauge.

Wire resistance in ohms vs. Length of cable run						
Distance in Feet	50'	100'	150'	200'	250'	300'
20 gauge	.86	1.73	2.59	3.45	4.32	5.18
18 gauge	.65	1.30	1.94	2.59	3.24	3.89
16 gauge	.43	.85	1.28	1.71	2.14	2.56
14 gauge	.27	.54	.81	1.08	1.35	1.62
12 gauge	.17	.34	.51	.68	.85	1.02
10 gauge	.11	.22	.33	.44	.56	.67

Installation

1. Start by separating the outer frame from the speaker by loosening the 4 mount screws until the speaker can be removed. Position and mark the speaker cut out template on the wall, cut out the speaker opening. There are 2 tabs located top right and bottom left to assist in removing the speaker from the frame.
2. Insert the speaker frame into the opening. Push in and turn each of the mount screws until each spring loaded tabs is released, this will hold the frame in place.
3. Connect the speaker wire to the positive and negative terminals push terminals.
4. Insert the speaker into the frame and tighten each mount screw until the speaker is secure DO NOT over tighten the mount screws. Install the grill cover.

1

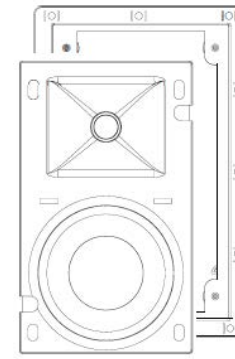

2

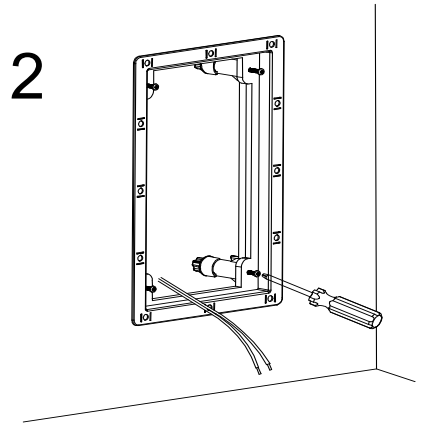

3

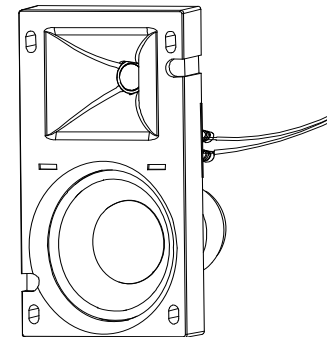

4

